



Government of Bermuda
Ministry of Public Works
Department of Works and Engineering

Addenda
For
**Prospect Maintenance Depot – Repair/Replace Metal Railings, Beams & Columns
and Painting**

Procurement No.: **2023-009Q-MPW**

Issued: **Thursday February 26, 2024**

Submission Deadline: **Wednesday, March 27, 2024, 03:00 P.M.**

Addenda No. **0004**

**Addenda Type: Repairs to Column Caps (Saddles) Revised Important Date,
Question and Answer**

The following addendum supersedes information contained in the solicitation document issued for this procurement to the extent referenced. This Addendum forms part of the solicitation documents and will be subject to all the conditions set out in the contract conditions.

- 1. The Submission Deadline is extended to April 12, 2024, 3:00 PM Local Time.**
- 2. Attached is drawing for Balcony Repairs**

End of Addenda No:0004

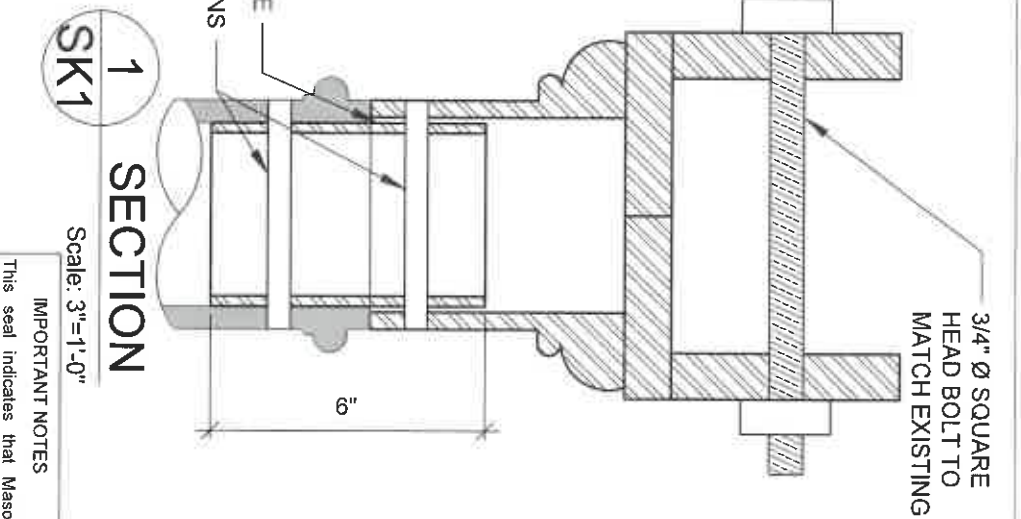
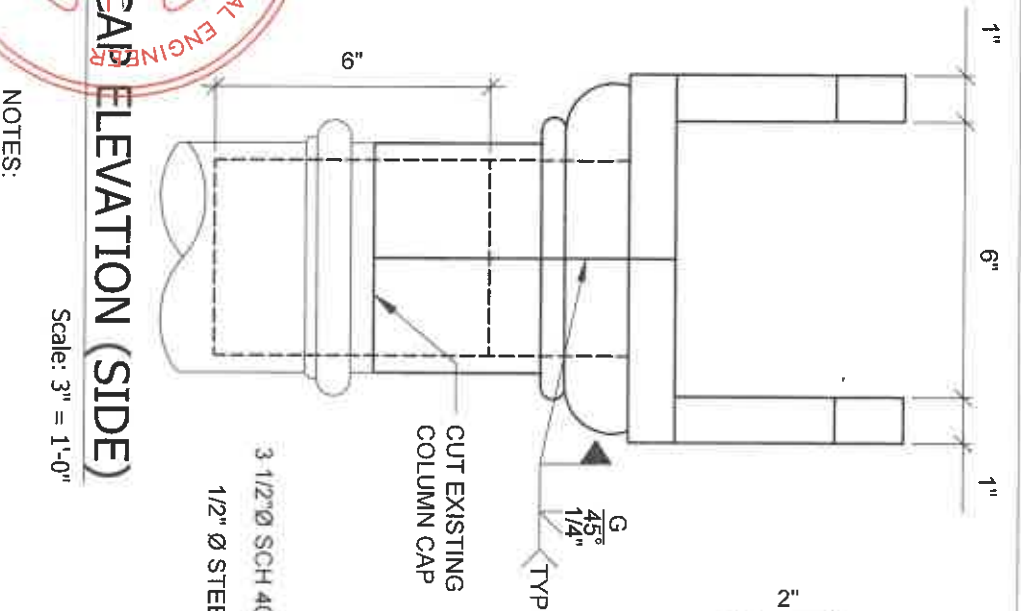
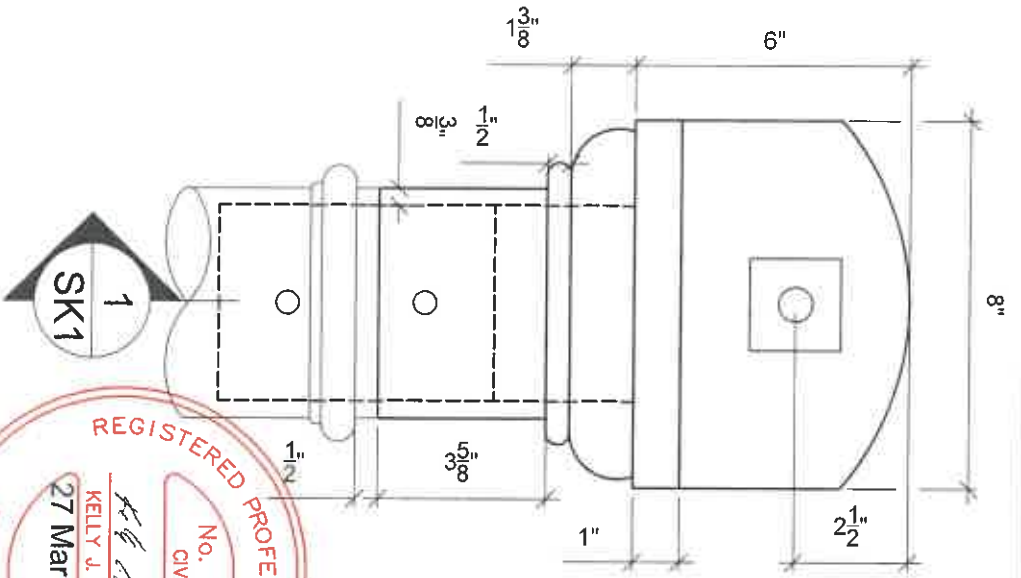

CAP ELEVATION (FRONT)

Scale: 3" = 1'-0"



CAP ELEVATION (SIDE)

Scale: 3" = 1'-0"

SECTION

Scale: 3" = 1'-0"

- NOTES:
1. BEAM TO BE ADEQUATELY SUPPORTED AND EXISTING CAP TO BE CUT.
 2. CAP TO BE FABRICATED IN TWO HALFS AND FITTED INTO PLACE.
 3. ORNAMENTAL DETAILS AND THICKNESS OF EXISTING COLUMN TO BE VERIFIED ON SITE.
 4. CORNER CAPS TO BE REPLACED IN SIMILAR MANNER.

IMPORTANT NOTES

This seal indicates that Mason and Associates Ltd. (MAL) has had direct or indirect input into specific design elements of the works. As such our company must be afforded the opportunity to inspect the work as it progresses to ensure conformity to the related design details, specifications and notes. If we are not accorded the privilege of inspecting the work on site before it is covered up or otherwise hidden or if variations to the original details are made without written approval by the engineer of record, Mason and Associates Ltd. will assume no responsibility for the works. Client is still required to contact Building Control for inspections.

PROJECT DETAILS

PROSPECT DEPOT BALCONY REPAIRS

MASON

AND ASSOCIATES LTD

13 Park-A-Ville Road, Hamilton HM 11

Phone: (441) 331-1981
Email: info@mason.bm
www.mason.bm

2 AEOLA DRIVE

DEVONSHIRE

TITLE

COLUMN CAP REPLACEMENT DETAIL

No.	DATE	BY	REVISION

DRAWN: KJH	SCALE: AS SHOWN
CHECKED: [Signature]	JOB NO: 15034
DATE: 25 MAR 24	DRAWING NO: SK1